

**Modular Cooking Range Line
EVO900 Gas Bratt Pan 100lt,
Automatic Tilting with Duomat
bottom**

ITEM # _____

MODEL # _____

NAME # _____

SIS # _____

AIA # _____

**392428 (Z9PPCSBAMGD)**

100-lt gas automatic tilting braising pan with Duomat cooking surface, thermostatic control, (Watermark & AGA) - Australia

Short Form Specification

Item No. _____

Suitable for natural gas or LPG. Burners in AISI 441 with flame failure device. Duomat cooking surface for roasting, browning, stewing, preparation of sauces, sautéing, boiling and braising. Can be installed on cantilever systems. Installation on wheels is not available. Includes mechanism to automatically tilt the pan and double-skinned lid in stainless steel. Cooking temperature can be set through thermostat and the energy input through an energy regulator. Exterior panels of unit in stainless steel with Scotch Brite finish. Right-angled side edges to allow flush-fitting junction between units.

Main Features

- Actual cooking temperature setting through adjustable thermostat.
- Smooth large surfaces, easy access for cleaning.
- Double-skin well and lid to reduce heat dispersion.
- Lid is double-lined, insulated in 20/10 Stainless steel.
- Energy input controlled by energy regulator.
- The special design of the control knob system guarantees against water infiltration.
- Automatic tilting mechanism to facilitate pan emptying.
- Bratt pan ideal for sautéing, poaching, steaming, boiling, stewing and damp cooking.
- Duomat cooking surface allows to perform wet and dry cooking alternatively.
- Working temperature can be set from 80 °C to 300 °C.

Construction

- All pan internal surfaces round and polished for better hygiene.
- All exterior panels in Stainless Steel with Scotch Brite finishing.
- Model has right-angled side edges to allow flush fitting joints between units, eliminating gaps and possible dirt traps.
- Burners in AISI 441 against corrosion and thanks to a high strength yield, are resistant to high temperature.
- Burners in chrome plated steel with flame failure device, optimized combustion and piezo ignition with electronic flame control.
- IPX5 water resistance certification.
- Cooking surface with **Duomat** bottom: a 10 mm-thick alloy obtained from the combination of 2 different stainless steels for better thermal stability and corrosion resistance.
- Usable capacity of the well 85 liters.

Sustainability

- Heat-insulated: limited heat radiation and low energy consumption.

APPROVAL: _____

Optional Accessories

- Draught diverter, 150 mm diameter PNC 206132
- Matching ring for flue condenser, 150 mm diameter PNC 206133
- Flanged feet kit PNC 206136
- Frontal kicking strip for concrete installation, 1000 mm PNC 206150
- Frontal kicking strip for concrete installation, 1200 mm PNC 206151
- Frontal kicking strip for concrete installation, 1600 mm PNC 206152
- Frontal kicking strip, 1000 mm PNC 206177
- Frontal kicking strip, 1200 mm PNC 206178
- Frontal kicking strip, 1600 mm PNC 206179
- Pair of side kicking strips PNC 206180
- 2 panels for service duct (single installation) PNC 206181
- 2 panels for service duct (back to back installation) PNC 206202
- 4 feet for concrete installation (not for 900 line freestanding grill) PNC 206210
- Chimney upstand, 1000 mm PNC 206305
- Rear paneling - 1000mm (EVO700/900) PNC 206375
- Rear paneling - 1200mm (EVO700/900) PNC 206376
- Chimney grid net, 200mm (EVO700&EVO900) PNC 206399
- Chimney grid net, 400mm PNC 206400
- Trolley with lifting and removable tank PNC 922403
- Pressure regulator for gas units PNC 927225

Front

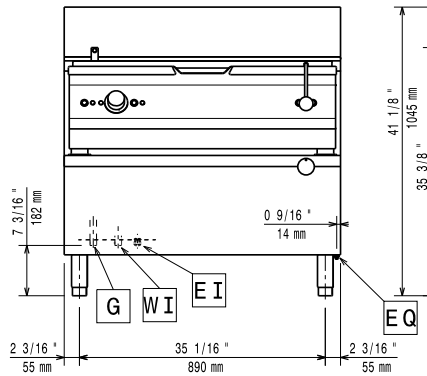

Side

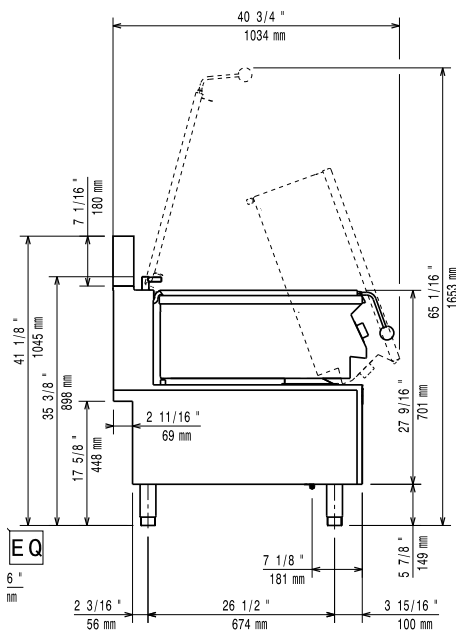

- CW11** = Cold Water inlet 1
- EI** = Electrical inlet (power)
- G** = Gas connection

Top

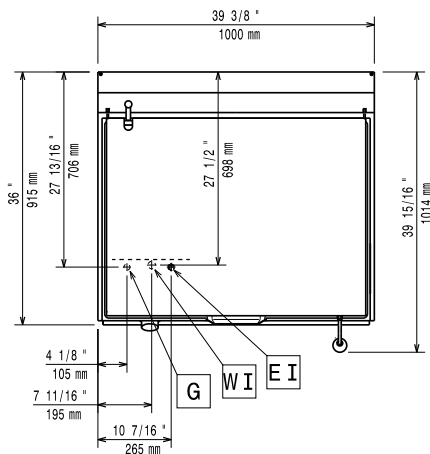

Gas

Natural gas - Pressure:	
392428 (Z9PPCSBAMGD)	7" w.c. (17.4 mbar)
LPG Gas Pressure:	11" w.c. (27.7 mbar)
Gas Power:	27 kW
Gas Type Option:	LPG; Natural Gas
Gas Inlet:	1/2"

Key Information:

No clearance needed on rear sides of unit if wall is of non combustible type. If wall is combustible, minimum 50 mm wall clearance should be maintained.

Cooking Surface Depth:	565 mm
Cooking Surface Width:	880 mm
Cooking Surface Thickness:	10 mm
Cooking Well Height:	180 mm
Well Capacity, Max:	100 lt
Working Temperature MIN:	80 °C
Working Temperature MAX:	300 °C
Net weight:	180 kg
Shipping weight:	197 kg
Shipping height:	1040 mm
Shipping width:	1100 mm
Shipping depth:	1020 mm
Shipping volume:	1.17 m ³